



AUTOMATIC LAWN MOVER USING NI- LABVIEW

D Naresh Kumar¹, V Arun¹, T Nagarjuna¹ Department of Electronics and Communication Engineering,
MLR Institute of Technology, Hyderabad, India² Department of Electronics and Communication Engineering,
Institute of Aeronautical Engineering, Hyderabad, India

Abstract: The main aim of this paper is to create Automatic lawn mover using Lab view. The remote Lawnmower could be a machine to create cutting grass method easier. The lawnmower's movement are going to be controlled by RF remote, wherever the transmitter circuit are going to be placed at the remote whereas the receiver circuit are going to be placed at the lawnmower. The signal are going to be transfer from the remote to the lawnmower by the antenna Joystick and also the signal transfer is by radio frequency signal (RF). RF is kind of effective in long distance and also the parts are low cost and straightforward to induce within the market. In this paper, transmitter and receiver circuit is build to manage the movement of the garden tool, motor and also the rotation of the blade. H-Bridge association is employed within the circuit so as to manage the lawnmower's movement whether or not to be slow or quick. There are 2 varieties of motor employed in this paper and each of it's DC motor

Keywords: There are 2 varieties of motor employed in this paper and each of it's DC motor

1. INTRODUCTION

The first lawn mower was invented by King Maudslayi in 1830 in Thrupp, merely outside Stroud, in county, England. The primary lawns weren't constantly distinguishable from pasture fields. The damp climate of maritime Western Europe at intervals the north created lawns achievable to grow and manage. Some forest areas where intensive grazing is practiced still have these semi natural lawns. For instance, within the New Forest, England, such touched area units are common, and area unit referred to as lawns, for instance Blamer field.

Labview is a graphical artificial language that uses icons rather than lines of text to make applications. science laboratory view uses dataflow programming, wherever the flow of knowledge determines execution. In work read, we will build a interface by employing a set of tools and objects. The interface is understood because the front panel. we tend to management the front panel objects by adding code in diagram.

3. HARDWARE COMPONENTS

3.1 Bluetooth module (HC-05):



Fig 2: HC-05 Bluetooth Module.

The HC-05 Bluetooth Module are progressing to be employed in associate degree passing Master or Slave configuration, creating it associate degree honest declare wireless communication. **THE AT CONFIG CODE:**

So as we tend to mentioned higher than, before we are able to send any AT commands to the module, we'd like to place it into the AT command mode. it'll vary



Figure 1: Olden days lawn mower

2. SOFTWARE

2.1. Introduction to Lab VIEW:

reckoning on your module, except for the HC-05 we'd like to tug pin thirty four high throughout power-up. If your module includes a button, connect everything up, however before connecting power to your board, and thus the module, hold the button in, and solely unleash it once you'll see the LEDs illumine. At this time, instead of quickly blinking, the crystal rectifier on the HC-05 can flash each a pair of seconds more or less.

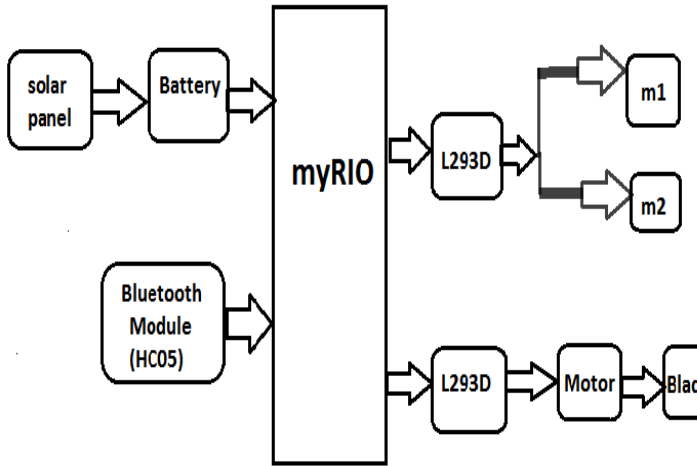

Fig 3. Block Diagram of Lawnmower

L293D:

A motor driver is associate computer circuit chip that's typically used to management motors in autonomous robots. Motor driver act as associate interface between Adriano and so the motors .the foremost typically used motor driver IC's unit from the L293 series admire L293D, L293NE, etc. These ICs unit designed to manage a pair of DC motors at the same time.

4. SOFTWARE PROGRAM

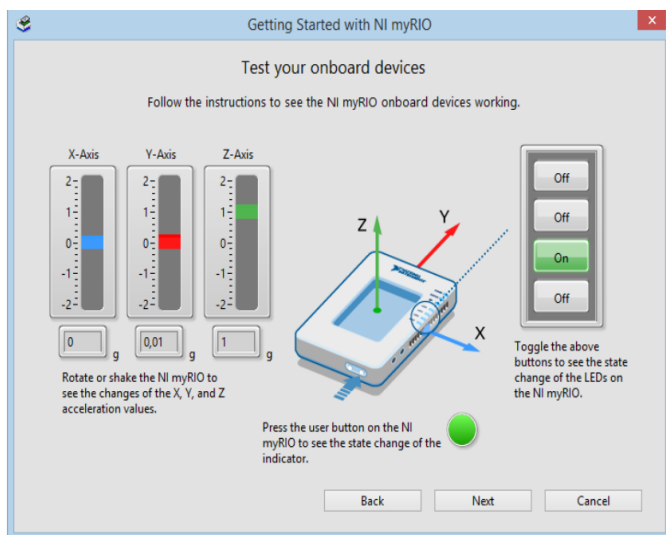

Fig 4 :Getting Started with NI myRIO

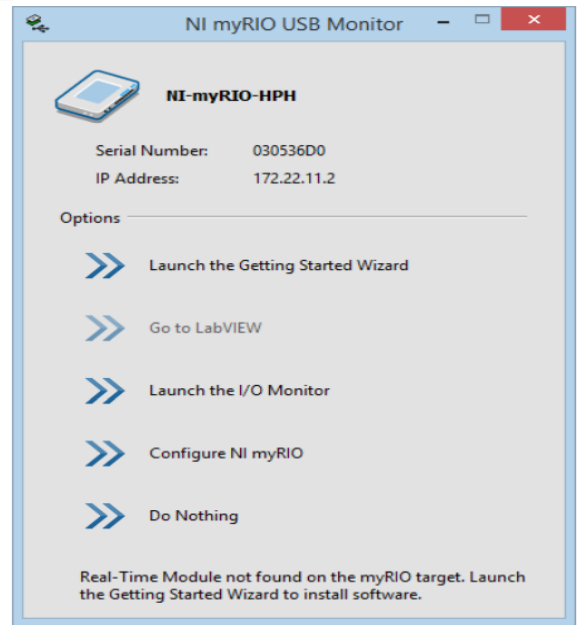

Fig 5: NI myRIO USB Monitor

5.RESULT

Connect The Wires With myRIO Connect the wires with NI myRIO. We connect the wire port A of the myRIO this myRIO attached to the (HC05) Bluetooth modue.And also L293D motors connected to the myRIO.

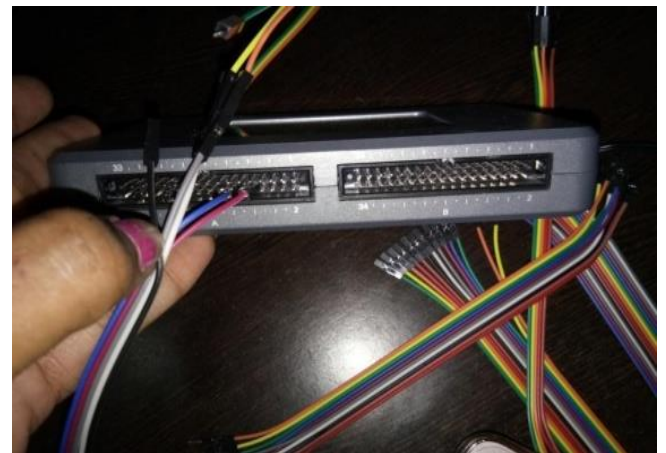

Fig 5: Connecting Wires

In this L293D motors are connected to the Jonson motor & solar panel. These wires attached to the battery and myRIO.We control the lawnmower by using the Bluetooth, give the directions by the mobile Bluetooth .that Bluetooth module was receive the message and reacted with in a second's.



Fig 6:Lawnmower

6. CONCLUSION & FUTURE SCOPE

A lawn mower which is simply called a grass cutter machine become very popular today and it very commonly used for furnishing soft grasses. Since it is easily operating machine so now it is used for various applications. This lawnmower is depending on the Bluetooth. In this we mainly check the myRIO then after we proceed the next level of the paper.

The solar lawn mower paper is designed to reduce the time and manual labour required for lawn clearing. The use of electronics and robotics helps by increasing the overall efficiency of the work done. The use of solar power makes this lawn mower more pollution free and cost effective. The concept of controlling the lawn mower by mobile/ pc solves the requirement of man's presence near the mowing site. The operation of movement can be governed and controlled through phone and also monitored on the computer screen through lab view. The study of photovoltaic voltages is also analyzed at different intervals of time throughout the day by the help of Lab view. In future this lawn

mower will be adjustable by using Dc motor. Bluetooth controlled can be operated from anywhere within the Bluetooth signal range by the mobile phone of the owner by using GSM.

7. REFERENCES

- [1] Al Williams (2002). Microcontroller papers using the Basic Stamp (2nd ed.). Focal Press. ISBN 978-1-57820-101-3.
- [2] "Use Proper Plumbing Tools To Avoid Flushing Money Down The Drain". Bangor Daily News. October 25, 1996. Retrieved 26 December 2013.
- [3] "Proper Replacement Of Gaskets Important". The Victoria Advocate. Feb 26, 1963. Retrieved December 26, 2013.
- [4] "Gaskets General – Non-Metallic Flat, Spiral Wound Gaskets, Camprofile Gaskets, Metal-Jacketed Gaskets and Metallic Gaskets -". wermac.org.
- [5] "You Can Fix Plumbing Problems With The Right Equipment". The Daily Courier. October 20, 1996. Retrieved December 27, 2013.
- [6] "Michelin Owner's manual" (PDF). November 2012. p. 14. Retrieved 9 November 2015.
- [7] Demere, Marc (25 June 2012). "6 Common Tire Myths Debunked". Popular Mechanics. Retrieved 14 July 2014.
- [8] Russell, Richard (16 December 2015). "How important is proper tire rotation?". The Globe and Mail. Retrieved 28 October 2016.
- [9] Crompton, T. R. (2000-03-20). Battery Reference Book (third ed.). Newnes. p. Glossary 3. ISBN 0080499953. Retrieved 2016-03-18.
- [10] Pauling, Linus (1988). "15: Oxidation-Reduction Reactions; Electrolysis.". General Chemistry. New York: Dover Publications, Inc. p. 539. ISBN 978-0-486-65622-9.
- [11] Pistoia, Gianfranco (2005-01-5). Batteries for Portable Devices. Elsevier. p. 1. ISBN 0080455565. Retrieved 2016-03-18.
- [12] www.rakeshmondal.info was founded on 2nd October 2012 by Rakesh Mondal. Rakeshmondal.info is an engineering website.