



## High Power Factor Interleaved Boost AC-DC Converter with ZVS for Charging Battery Operated Vehicles

K. SivaRaman\* and B.Vaidyanathan  
PG scholar\*, Assistant Professor

Electrical & Electronics Engineering Bharath University, India  
[sivaraman2777@gmail.com](mailto:sivaraman2777@gmail.com), [vaidia555@sify.com](mailto:vaidia555@sify.com)

**Abstract:** The aim of the project is to develop a high power factor and efficient AC-DC converter suitable for charging batteries that are used in electric vehicles. The energy conversion during the battery charging is performed by an ac/dc converter. Boost converters are generally used to realize input PFC and ac/dc conversion. In high power applications, interleaving continuous current mode PFC boost stages are used. A novel, yet simple zero-voltage switching (ZVS) interleaved boost power factor correction (PFC) ac/dc converter used to charge the traction battery of an electric vehicle from the utility mains is proposed here. The proposed converter implements soft switching through a simple passive auxiliary circuit placed in between the two phases of the interleaved boost converter. This auxiliary circuit provides reactive current during the transition times of the MOSFETs to charge and discharge the output capacitors of the MOSFETs. In addition, the control system effectively optimizes the amount of reactive current required to achieve ZVS for the power MOSFETs. This optimization is crucial in this application since the converter may work at very light loads for a long period of time. The proposed converter maintains ZVS for the universal input voltage, which includes a very wide range of duty ratios.

**Key words:** AC/DC converter, continuous current mode (CCM), dc/dc converter, interleaved boost converter, power factor correction (PFC), zero-current switching (ZCS), zero-voltage switching (ZVS).

### I. INTRODUCTION

Electric vehicle (EV) power conditioning systems usually utilize a high-energy battery pack to store energy for the electric traction system. This energy conversion during the battery charging is performed by an ac/dc converter. Such ac/dc converters, which are used to charge the high-energy battery, usually consist of two stages: front-end boost converter, which performs input PFC and ac/dc conversion, and full-bridge dc/dc converter for battery charging and galvanic isolation. PFC is essential to improve the quality of the input current, which is drawn from the utility. Boost converters are generally used to realize input PFC and ac/dc conversion in the front end of an ac/dc converter. In high power applications, interleaving continuous current mode (CCM) PFC boost stages, is a very common approach to effectively decrease the inductor footprint and volume as well as the output capacitor current ripple[1]-[3]. A typical boost PFC utilizes a switch and a diode.

The main sources of switching losses in boost PFC converters are hard turn-ON of the MOSFET and the reverse recovery of the boost diode during its turn-OFF. In order to eliminate the switching losses in a MOSFET-based boost PFC converter, different auxiliary circuits have been proposed [7]-[9]. Commonly, these auxiliary circuits consist of a combination of passive components such as small inductors and capacitors and additional active components such as MOSFETs and diodes. Auxiliary circuits in ZVS-pulse width modulation (PWM) single-switch converters are generally one of two types, non resonant and resonant, depending on whether there is an LC resonant network placed in series with the switch. There is a third type, dual auxiliary circuits, that is a combination of both resonant and non resonant circuits[4]-[6]. The auxiliary switch is turned ON just before the main converter switch is to be turned ON. The auxiliary switch is used to discharge the capacitor across the main switch so that it can turn ON with ZVS.

The auxiliary switch is turned OFF shortly after the main switch is turned ON, and all the energy in the auxiliary circuit is eventually transferred to the output. After this is done, the auxiliary circuit is fully deactivated and the converter operates like a conventional PWM converter. The components in the auxiliary circuit have lower ratings than those in the main power circuit because the circuit is active for a fraction of the switching cycle. This allows a device that can turn ON with fewer switching losses than the main switch to be used as the auxiliary switch. The addition of an active auxiliary circuit to a PWM converter can also eliminate the reverse-recovery current of the main power boost diode. The auxiliary circuits have an inductor located in series with the auxiliary switch. This allows current to be gradually transferred away from the boost diode to the auxiliary switch when it is turned ON so that the charge in the diode is slowly removed during turn-OFF; with such a gradual transition from conduction state to OFF-state of the diode, its reverse-recovery current can be greatly reduced, thus, eliminating reverse recovery losses.

### II. PROPOSED SYSTEM

In this project, a novel interleaved boost PFC converter is proposed to achieve soft switching in the main switches of the converter. In the proposed topology, two boost cells each with a single main MOSFET switch are interleaved. For each main switch an auxiliary MOSFET switch along with a common RL circuit is provided in order to resonate with filter capacitor to achieve ZVS (Zero Voltage Switching) of main switches. This auxiliary circuit is able to provide reactive current to charge and discharge the output capacitors of the boost MOSFETs and guarantee ZVS. The interleaved boost converter converts the rectified input voltage to the intermediate dc-bus voltage. The proposed converter maintains ZVS for the universal input voltage (85

to 265 Vrms), which includes a very wide range of duty ratios.

Since there are no extra semiconductors used in the auxiliary circuit, high efficiency and reliability are produced. In addition, the proposed converter is able to optimize the amount of reactive current required to implement soft switching based on the load condition and the input voltage. The soft-switching boost converter approach combines PWM mode and resonant mode techniques. A topology that operates in PWM mode during most of the switching cycle, but operates in a resonant mode during the main boost switch turn on and turn-off intervals.

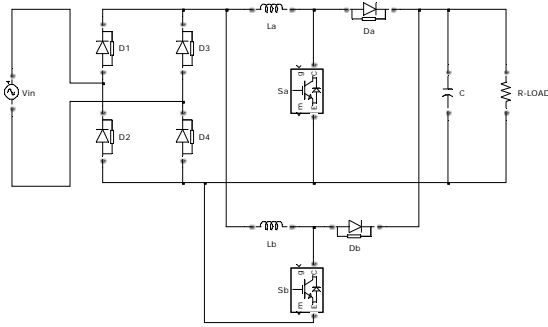

Figure. 2.1 Proposed topology

As a result, zero voltage switching (ZVS) takes place in both the boost switch, as well as the output diode, and, in so doing, reduces the switching losses encountered by hard switched boost converters. In this converter, two boost converters operate with 180° phase shift in order to reduce the input current ripple of the converter. This 180° phase shift can be used to provide reactive current for realizing ZVS for power MOSFETs.

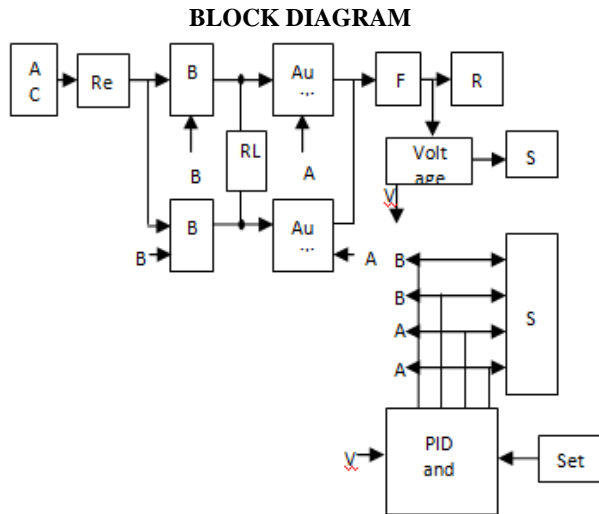

Figure. 2.2. Block Diagram

This auxiliary circuit consists of a HF inductor and a dc-blocking capacitor. Since there may be a slight difference between the duty ratios of the two phases, this dc-blocking capacitor is necessary to eliminate any dc current arising from the mismatch of the duty ratios of the main switches. The voltage measurement block is used to measure the voltages. Then the output voltage can be used by another Simulink block (SCOPE). The closed PID control is also

provided to achieve the desired output voltage. The output waveform is displayed by using scope.

The 230Vac supply is rectified to dc supply by using a rectifier. The dc input is given to the boost circuit. Two boost cells with a single MOSFET as a main switch is interleaved in this topology to obtain ZVS condition. For each main switch an auxiliary MOSFET switch along with a common RL circuit is provided in order to resonate with filter capacitor to achieve ZVS (Zero Voltage Switching) of main switches. The auxiliary circuits have an inductor located in series with the auxiliary switch. This allows current to be gradually transferred away from the boost diode to the auxiliary switch when it is turned ON. All MOSFETs of the interleaved boost converter are turned ON under zero voltage and the output MOSFETs are turned OFF at nearly zero current. This implies that the MOSFETs enjoy having near-zero switching losses. In order to guarantee ZVS for the MOSFETs, the inductive current of the auxiliary circuit should be enough to neutralize the input current and discharge and charge the output capacitors of the MOSFETs during turn-ON times of BG1 and BG2.

Also, the dead time between the gate pulses should be enough to allow complete charging and discharging of the output capacitors of the switches. Therefore, first the auxiliary inductor should be designed so as to provide enough inductive current to charge and discharge the capacitors, then the dead time should be properly adjusted to have enough time to complete the charge and discharge. Since the input current helps to charge and discharge the output capacitors of AG1 and AG2, ZVS is automatically guaranteed for AG1 and AG2. The proposed auxiliary circuit can effectively cancel out the positive current imposed by the input inductor during the MOSFET turn-ON times and completely eliminate the turn-ON losses of the boost MOSFET. In addition, the auxiliary inductor current brings down the current prior to the output MOSFET turn-OFF times; hence, the output MOSFET undergoes near zero-current switching (ZCS) turn-OFF. Therefore, the switching losses are almost zero in the proposed converter. The output is filtered and connected to R-Load. The output voltage is viewed through the scope

### III. ANALYSIS

The power circuit of the ZVS interleaved boost PFC converter. In this converter, two boost converters operate with 180° phase shift in order to reduce the input current ripple of the converter. This 180° phase shift can be used to provide reactive current for realizing ZVS for power MOSFETs. This auxiliary circuit consists of a HF inductor and a dc-blocking capacitor. Since there may be a slight difference between the duty ratios of the two phases, this dc-blocking capacitor is necessary to eliminate any dc current arising from the mismatch of the duty ratios of the main switches in the practical circuit.

The key waveforms of the converter for  $D > 0.5$ . According to this figure, there are eight operating modes in one switching cycle of the converter. The operating modes are explained as follows.

#### A. Mode I ( $t_0 < t < t_1$ ):

This mode starts when the gate pulse is applied to SA1. Once the voltage is applied to the gate, SA1 is turned ON under zero voltage. Since SA1 and SB 1 are ON during this

interval, the voltage across the auxiliary inductor is zero. Thus, the current through the auxiliary circuit remains constant at  $I_{Aux,p}$ .

**B. Mode II ( $t1 < t < t2$ ):**

This mode is the dead time between the phase B MOSFETs. During this interval, the auxiliary circuit current charges the output capacitance of SB 1 and discharges the output capacitance of SB 2. In this mode, the average voltage across the boost inductance LB is zero. Therefore, the current through LB remains constant at its peak value.

**C. Mode III ( $t2 < t < t3$ ):**

Once the output capacitors of SB 1 and SB 2 have been charged and discharged completely, the gate signal of SB 2 is applied and SB 2 is turned ON under ZVS. During this interval, the voltage across the auxiliary circuit is  $-V_o$ . The current through the auxiliary inductor, inductor LA

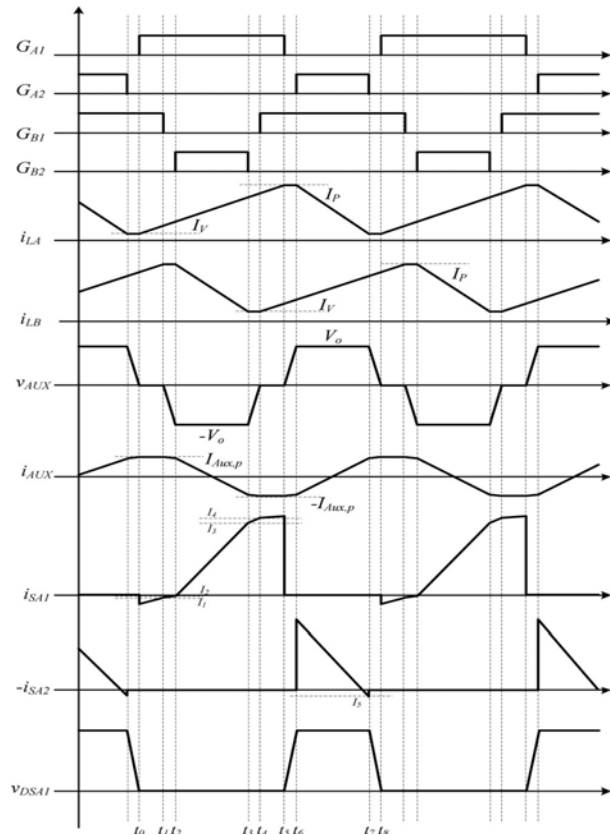

Figure 3.2 Key waveforms of the converter for  $D > 0.5$ .

**D. Mode IV ( $t3 < t < t4$ ):**

During this mode, the output capacitor of SB 2 is charging from zero to  $V_o$  and the output capacitor of SB 1 is discharging from  $V_o$  to zero. This period is actually the dead time between SB 2 and SB 1 ( $t4 - t3 = td$ ). The auxiliary inductor current, the boost inductor current, and the switch current, during this mode.

**E. Mode V ( $t4 < t < t5$ ):**

This mode starts when the gate signal is applied to SB 1. Once the gate has been applied, SB 1 is turned ON under ZVS. Since SA1 and SB 1 are ON during this period, the voltage across the auxiliary inductor is zero; hence, the auxiliary inductor current remains constant at its peak value,

$I_{Aux,p}$ . The boost inductor current and the switch current, during this mode

**F. Mode VI ( $t5 < t < t6$ ):**

During this mode, the output capacitor of SA1 is charging from zero to  $V_o$  and the output capacitor of SA2 is discharging from  $V_o$  to zero. This period is actually the dead time between SA1 and SA2 ( $t6 - t5 = td$ ). In this period, the current through the boost inductor LA remains constant at its peak value.

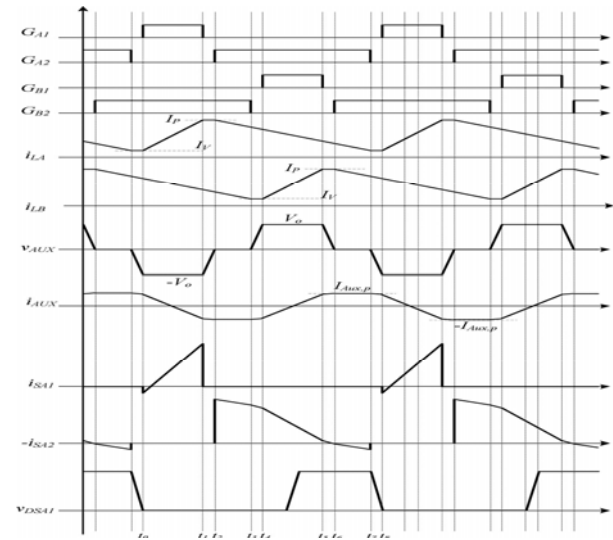

Figure 3.3. Key waveforms of the converter for  $D < 0.5$ .

**IV. SIMULATION RESULTS**

The High Power Factor Interleaved Boost AC-DC Converter with ZVS for Charging Battery Operated Vehicles is simulated using Matlab simulink and their results are presented here. The circuit model of resonant converter is shown in Fig.4

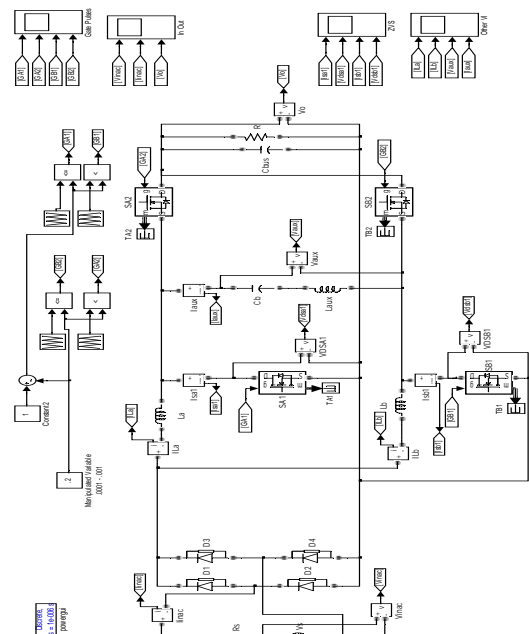

Figure 4.10 Open Loop Circuit

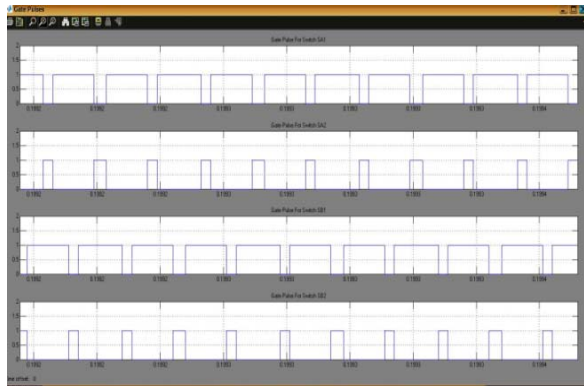

Figure 4.2 Open loop Gate pulses

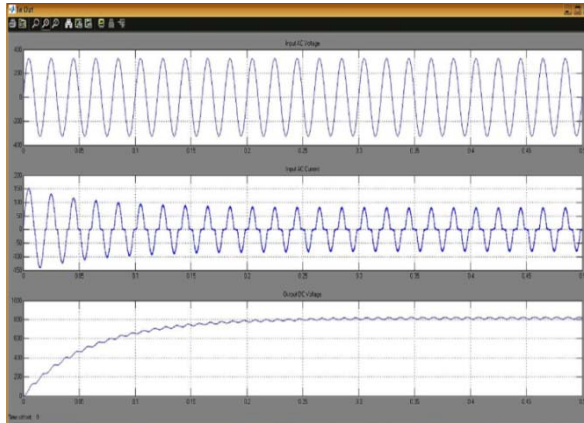

Figure 4.3 Open loop In out VI

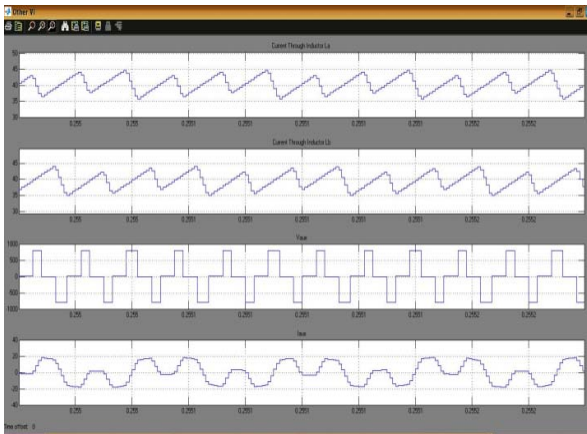

Figure 4.4 Open loop inductor and auxiliary VI



Figure 4.5 Open loop ZVS

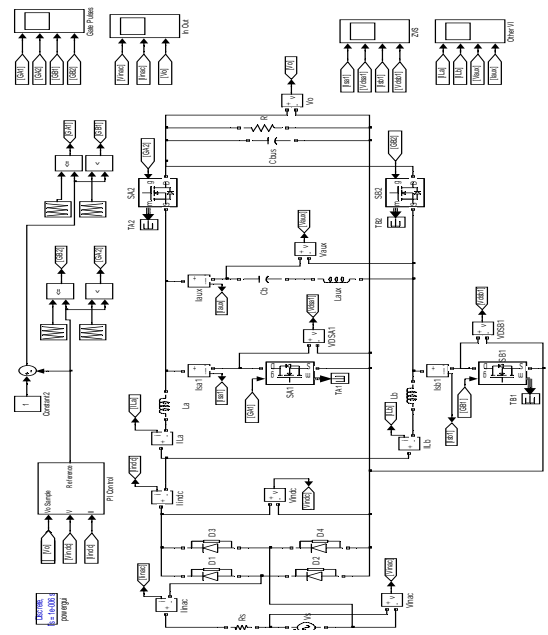

Figure 4.6 Closed Loop Simulation

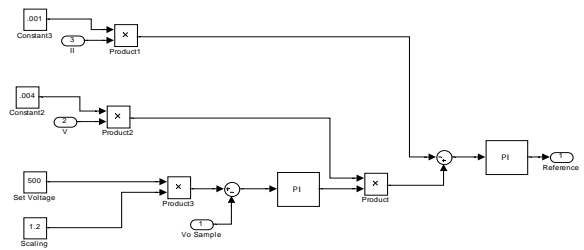

Figure 4.7 Closed loop PI control

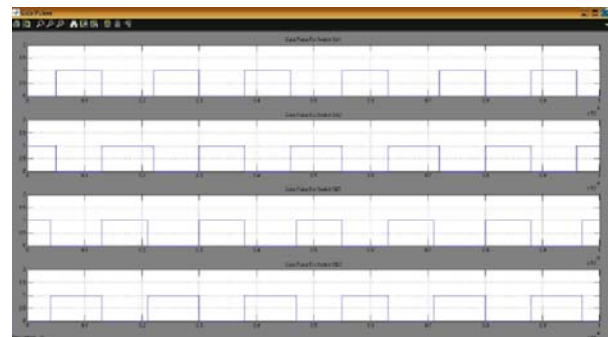

Figure 4.8 Closed loop Gate Pulses

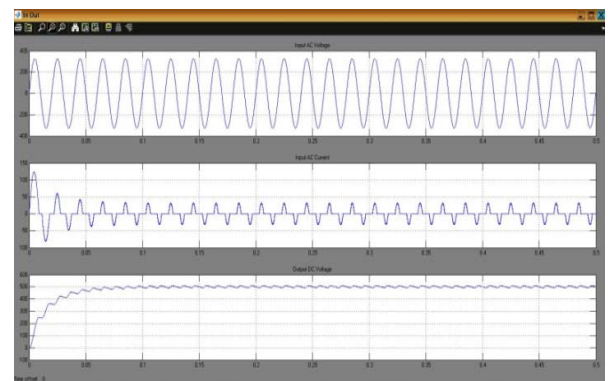

Figure 4.9 Closed loop In Out VI

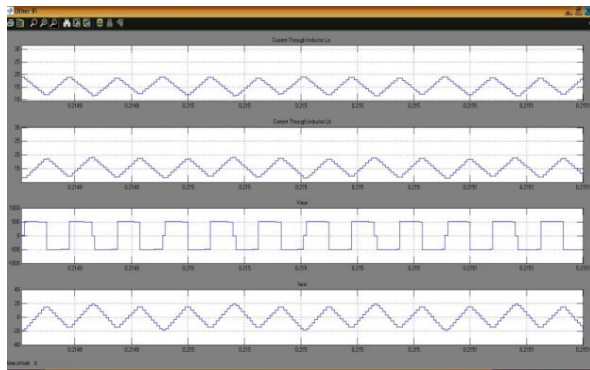

Figure 4.10 Closed Loop Inductor and Auxiliary VI

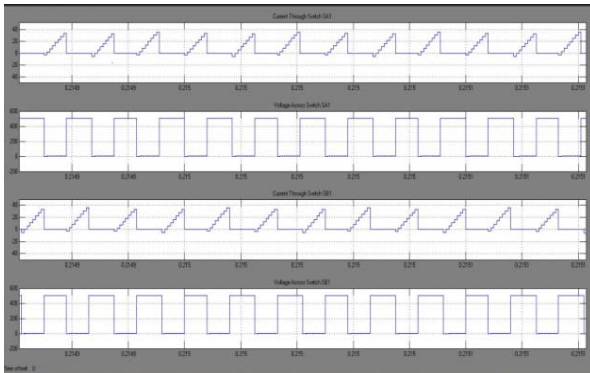

Figure 4.11 Closed loop ZVS

## V. CONCLUSION

Thus a high power factor and efficient AC-DC converter suitable for charging batteries that are used in electric vehicles was designed with a interleaved boost PFC converter, which provides soft switching for the power MOSFETs, through an auxiliary circuit. This auxiliary circuit provides reactive current during the transition times of the MOSFETs to charge and discharge the output capacitors of the MOSFETs. In addition, the control system effectively optimizes the amount of reactive current required to achieve ZVS for the power MOSFETs. The frequency loop, which is introduced in the control system, determines the frequency of the modulator based on the load condition and the duty cycle of the converter.

## VI. FUTURE ENHANCEMENTS

Closed loop control can be employed by sensing the load voltage and fed to ADC of microcontroller. Then the load voltage can be compared with a set value and the error signal can be used to modify the duty ratio of boost cells to achieve the desired load voltage

## VII. ACKNOWLEDGEMENT

With profound sense and regards, I acknowledge with great pleasure the guidance and support extended by Mrs. V. Jayalakshmi, Assistant Professor and Head, Department of Electrical and Electronics and Engineering, for the support, encouragement and the facilities provided to me during this project. I express heartfelt thanks to my project guide Mr. B. Vaidiyanathan, Assistance professor, Department of Electrical and Electronics and Engineering, for her continual guidance & support with her suggestion for the successful completion of the project

## VIII. REFERENCES

- [1]. R. Giral, L. Martinez-Salamero, and S. Singer, "Interleaved converters operation based on CMC," IEEE Trans. Power Electron., vol. 14, no. 4, pp. 643–652, Jul. 1999.
- [2]. Y. Jang and M. M. Jovanovic, "Interleaved boost converter with intrinsic voltage-doubler characteristic for universal-line PFC front end," IEEE Trans. Power Electron., vol. 22, no. 4, pp. 1394–1401, Jul. 2007.
- [3]. G. Moschopoulos, P. Jain, G. Joos, and Y.-F. Liu, "Zero voltage switched PWM boost converter with an energy feedforward auxiliary circuit," IEEE Trans. Power Electron., vol. 14, no. 4, pp. 653–662, Jul. 1999.
- [4]. T.-W. Kim, H.-S. Kim, and H.-W. Ahn, "An improved ZVT PWM boostconverter," in Proc. Conf. Rec. IEEE Power Electron. Spec. Conf., 2000, pp. 615–619.
- [5]. N. Jain, P. Jain, and G. Joos, "A zero voltage transition boost converter employing a soft switching auxiliary circuit with reduced conduction losses," IEEE Trans. Power Electron., vol. 19, no. 1, pp. 130–139, Jan. 2004.
- [6]. C.-M. Wang, "A novel zero-voltage-switching PWM boost rectifier with high power factor and low conduction losses," IEEE Trans. Ind. Electron., vol. 52, no. 2, pp. 427–435, Apr. 2005.
- [7]. G. Yao, A. Chen, and X. He, "Soft switching circuit for interleaved boostconverters," IEEE Trans. Power Electron., vol. 22, no. 1, pp. 80–86, Jan. 2007.
- [8]. B.-R. Lin, H.-K. Chiang, C.-Y. Tung, and C.-Y. Cheng, "Implementation of an interleaved ZVS boost-type converter," in Proc. IEEE Int. Symp. Ind. Electron., Jul. 5–8, 2009, pp. 819–824.
- [9]. H. Yao-Ching, H. Te-Chin, and Y. Hau-Chen, "An interleaved boost converter with zero-voltage transition," IEEE Trans. Power Electron., vol. 24, no. 4, pp. 973–978, Apr. 2009.